BK3231 Bluetooth HID SoC Datasheet

Objective Specification

Beken Corporation
3A,1278KeyuanRd,Zhangjiang High-Tech Park
Pudong new Distrinct,Shanghai,201203,china
Tel: (86)21 51086811
Fax: (86)21 60871277

This document contains information that may be proprietary to, and/or secrets of, Beken Corporation. The contents of this document should not be disclosed outside the companies without specific written permission.

Disclaimer: Descriptions of specific implementations are for illustrative purpose only, actual hardware implementation may differ.

Revision History

Version	Date	Author(s)	Description
0.1	23/Mar/2012	Weifeng	Initial Draft
	17/Oct/2012	Weifeng	Update for MP pin assignment for keyboard, with additional JTAG at cost of 5 less GPIOs
	29/Nov/2012	LiangHuang	Update pin description

Table of Contents

1	General Description	6
2	Features	6
3	Block Diagram	7
4	PIN information	8
5	Electrical Specifications.....	11



List of Figures

FIGURE 1BK3231 BLOCK DIAGRAM	7
FIGURE 2BK3231QFN56PIN ASSIGNMENT	8



List of tables

TABLE1BK3231 QFN56 PIN DESCRIPTION 8

1 General Description

The BK3231 chip is a highly integrated single-chip Bluetooth HID device. It integrates the high-performance transceiver, rich features baseband processor, and Bluetooth HID profile.

2 Features

- Operation voltage from 2.8 V to 3.6 V
- Bluetooth 2.1 compliant
- -88dBm sensitivity for 1 Mbps mode and 2 dBm transmit power
- HID v1.0
- 16 MHz crystal reference clock
- 56-pin QFN 7mmx7mm package for keyboard
- I2C, SPI and UART interface

3 Block Diagram

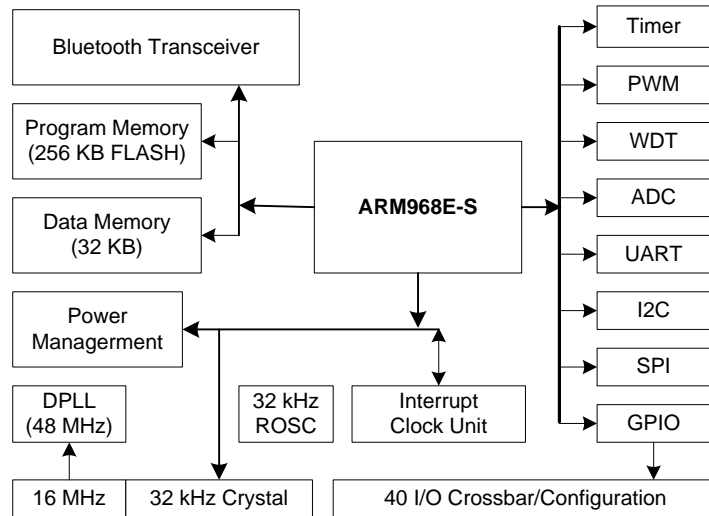

Figure 1BK3231 Block Diagram

4 PIN information

The next diagram shows QFN56 format for the full functions usage. It can be used as keyboard TX part and total 35 GPIO available.

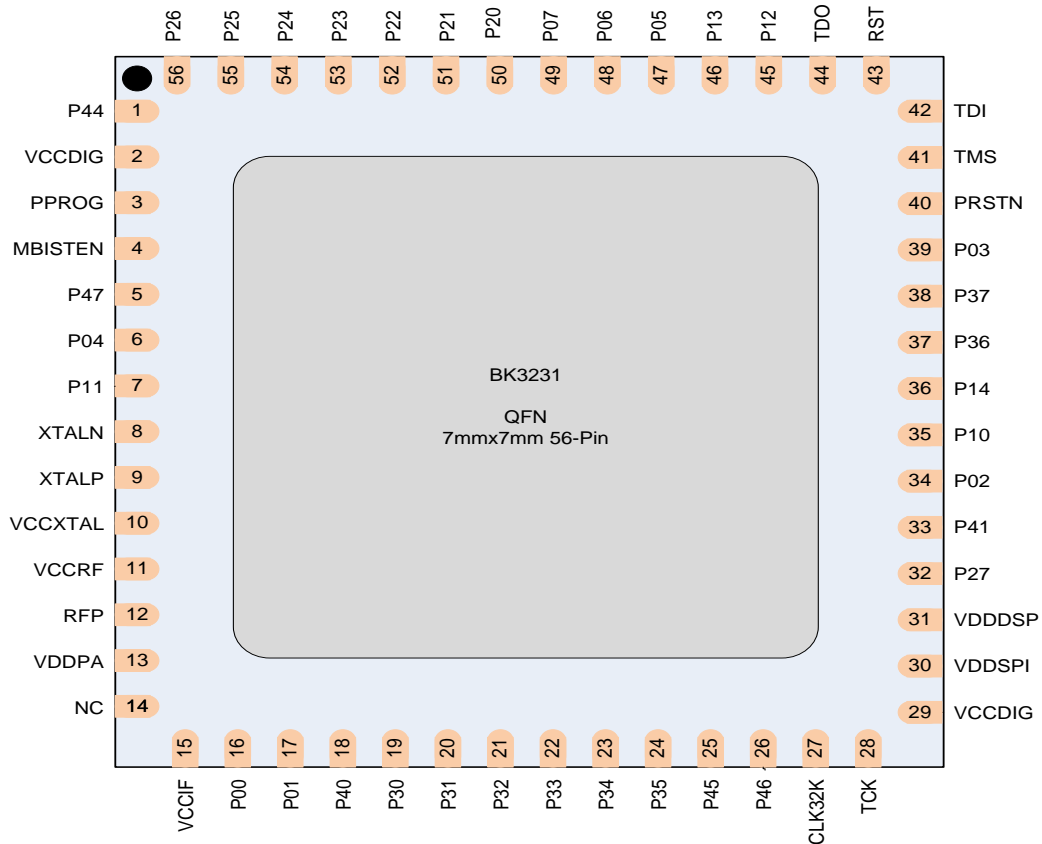

Figure 2BK3231QFN56Pin Assignment

Table1BK3231 QFN56 pin description

PIN	Name	Pin Function	Description
1	P44	Digital I/O	General I/O
2	VCCDIG	Power supply	3 V supply
3	PPROG	Digital I/O	FLASH programming selection
4	MBISTEN	Digital I/O	Test enable
5	P47	Digital I/O	General I/O
6	P04	Digital I/O	General I/O, or MOSI for SPI
7	P11	Digital I/O	General I/O, or input for external active low interrupt
8	XTALN	Analog output	Oscillator output
9	XTALP	Analog input	Oscillator input
10	VCCXTAL	Power supply	3 V supply
11	VCCRF	Power supply	3 V supply



BK3231

v0.1

12	RFP	RF port	RF input and output
13	VDDPA	Power output	1.8 V supply to PA
14	NC	NC	Not connected
15	VCCIF	Power supply	3 V supply
16	P00	Digital I/O	General I/O
17	P01	Digital I/O	General I/O
18	P40	Digital I/O	General I/O
19	P30	Digital I/O or analog input	General I/O
20	P31	Digital I/O or analog input	General I/O, or input of ADC1
21	P32	Digital I/O or analog input	General I/O, or input of ADC2
22	P33	Digital I/O or analog input	General I/O
23	P34	Digital I/O or analog input	General I/O, or input of ADC4
24	P35	Digital I/O or analog input	General I/O, or input of ADC5
25	P45	Digital I/O	General I/O
26	P46	Digital I/O	General I/O
27	CLK32K	Analog input	Clock 32 kHz input
28	TCK	Digital I/O	JTAG pin
29	VCCDIG	Power supply	3 V supply
30	VDDSPI	Analog output	Power output, connected with decoupling CAP
31	VDDDSP	Analog output	Power output, connected with decoupling CAP
32	P27	Digital I/O	General I/O, or enable for PWM1
33	P41	Digital I/O	General I/O
34	P02	Digital I/O	General I/O
35	P10	Digital I/O	General I/O, or input for external interrupt 0, active low
36	P14	Digital I/O	General I/O
37	P36	Digital I/O	General I/O, or input of ADC6
38	P37	Digital I/O	General I/O, or input of ADC7
39	P03	Digital I/O	General I/O
40	PRSTN	Digital I/O	Active low whole chip reset
41	TMS	Digital I/O	JTAG pin
42	TDI	Digital I/O	JTAG pin
43	RST	Digital I/O	JTAG reset
44	TDO	Digital I/O	JTAG pin
45	P12	Digital I/O	General I/O
46	P13	Digital I/O	General I/O
47	P05	Digital I/O	General I/O, or MISO for SPI
48	P06	Digital I/O	General I/O, or SCK for SPI
49	P07	Digital I/O	General I/O, or chip select for SPI
50	P20	Digital I/O	General I/O, or input for UART
51	P21	Digital I/O	General I/O, or output for UART
521	P22	Digital I/O	General I/O
53	P23	Digital I/O	General I/O, or clock for SMBUS (I2C)



BK3231

v0.1

54	P24	Digital I/O	General I/O, or data I/O for SMBUS (I2C)
55	P25	Digital I/O	General I/O
56	P26	Digital I/O	General I/O, or enable for PWM0

5 Electrical Specifications

Table 1 RF Characteristics

Name	Parameter (Condition)	Min	Typical	Max	Unit	Comment
Operating Condition						
VCC	Voltage	1.7	3.0	3.6	V	
TEMP	Temperature	-40	+27	+85	°C	
Digital input Pin						
VIH	High level	VCC-0.3		VCC+0.3	V	
VIL	Low level	VSS		VSS+0.3	V	
Digital output Pin						
VOH	High level (IOH=-0.25mA)	VCC- 0.3		VCC	V	
VOL	Low level(IOL=0.25mA)	VSS		VSS+0.3	V	
Normal condition						
IVDD	Power Off		-	2	uA	
IVDD	Sleep current (RF OFF, 32 kHz clock)			10	uA	
IVDD	Active RX			26	mA	
IVDD	Active TX @ 2 dBm output power			24	mA	
Normal RF condition						
FOP	Operating frequency	2400		2480	MHz	
FXTAL	Crystal frequency		16		MHz	
RFSK	Air data rate		1		Mbps	
Transmitter						
PRF	Output power	-40	0	5	dBm	
PBW	Modulation 20 dB bandwidth			1	MHz	
PRF1	Out of band emission 2 MHz		-20		dBm	
PRF2	Out of band emission 3 MHz		-40		dBm	
IVDD	Current at -40dBm output power				mA	
IVDD	Current at -30dBm output power				mA	
IVDD	Current at -25dBm output power				mA	
IVDD	Current at -10dBm output power				mA	
IVDD	Current at -5dBm output power				mA	
IVDD	Current at 0dBm output power				mA	
IVDD	Current at 2dBm output power		24		mA	
Receiver						
Max Input	1 E-3 BER	-20		10	dBm	
RXSENS	1 E-3 BER sensitivity		-88		dBm	
IIP3	IIP3, Pin=-63 dBm; P _{unwant} =-39 dBm; f ₀ =2f ₁ -f ₂ , f ₂ -f ₁ =3 MHz or 4 MHz or 5 MHz	-21	-16		dBm	
C/ICO	Co-channel C/I			11	dB	
C/I1ST	ACS C/I 1MHz			0	dB	
C/I2ND	ACS C/I 2MHz			-30	dB	
C/I3RD	ACS C/I 3MHz			-40	dB	
C/I1STI	ACS C/I Image channel			-9	dB	
C/I2NDI	ACS C/I 1 MHz adjacent to image channel			-20	dB	



Table 2MCU Characteristics

Name	Parameter (Condition)	Min	Typical	Max	Unit	Comment
	Core functions					
	Deep sleep mode		2		uA	
	Sleep mode (RCOSC 32k)		6		uA	
	Idle mode at 16 MHz		1		mA	
	Idle mode at 8MHz		0.8		mA	
	Idle mode at XOSC32k (16 MHz running)		0.15		mA	
	Active mode (16 M)		4.9		mA	
	Active mode (8M)		3.9		mA	